



SINGER VALVE

Result-Based Solutions. Globally.™

Model 106-SPI-MV Single Point Insertion Flow Metering Valve

***The next
generation of
in-valve flow
measurement***



Model 106-SPI-MV Single Point Insertion Flow Metering Valve

Don't settle for less!



With over 100 years of combined waterworks experience, Singer Valve and McCrometer have teamed up to provide a unique solution for in-valve flow measurement. Using McCrometer's proven Single Insertion Meter technology along with the reliability of a Singer Valve, it allows users to have both a flow meter solution along with any function of control valve.

Whether it is pressure reducing, level control, or sustaining - all can be installed now with a very accurate flow meter solution.

By adding dual solenoid control to the pilot system and utilizing the Singer MCP Multi Channel PLC Controller, we now have a fully automated control system able to control to any input required and all able to function within your existing SCADA system.

Unprecedented Engineering Design

The Singer Model 106-SPI-MV is a Single Point Insertion Electromagnetic Flow Meter, installed and calibrated in conjunction with a Singer Valve to provide an accurate flow rate that can be utilized with the metering valve as a stand alone option or built into a 106-2SC-PCO pilot system to provide complete flow-based valve control.

The sensor is available for one-inch taps, depending upon valve size and application.

The compact insertion design fits in confined spaces and offers complete accessibility. The flow meter can be removed for easy inspection, cleaning, calibrating or verification.

This cost effective flow meter option is available for valve sizes from 4" (100mm) to 36" (900mm) inches. The flow sensor comes pre-calibrated from McCrometer's NIST traceable Calibration Lab and requires no recalibration in the field. With no moving parts and a single-piece design, the SPI Mag's sensor contains nothing to wear or break, and it is generally immune to clogging by sand, grit or other debris.

The 106-SPI-MV Mag is profiled for the valve body, further enhancing its measurement accuracy by allowing precise determination of mean velocities.



KEY FEATURES

- Accurate flow metering, combined with control valve to save space/cost
- Supplied with Flow Convertor for local display with 4-20mA output measurement or can be combined with PLC-based control panel for flow control applications
- +/- 2% of rate accuracy, NIST traceable

Model 106-SPI-MV

Single Point Insertion Flow Metering Valve

Measurement

Volumetric flow in valves 4" (100mm) to 36" (900mm) diameter utilizing insertable velocity sensor. Flow indication in English Standard or Metric units.

Flow Measurement

Method: Electromagnetic

Accuracy: $\pm 2\%$ of reading ± 0.03 ft/s (± 0.009 m/s) zero stability from 0.3 to 32 ft/s (0.09 to 10 m/s) velocity range

Velocity Range: +0.3 to +32 ft/s (+0.09 to +10 m/s) Has reverse flow indication.

Conductivity

Minimum conductivity of 5 μ S/cm

Power Requirements

AC: 90-265V 45-66 Hz (20W/25VA) or

DC: 10-35V (21W)

AC or DC must be specified at time of ordering.

Materials

Sensor: Polyurethane exposed to flow

Sensor Mounting: Stainless Steel exposed to flow.

Compression Seal: Buna "N" O-Ring seal exposed to flow.

Outputs

Dual 4-20mA Outputs: Galvanically isolated and fully programmable for zero and full scale (0-21mA) Four separate digital programmable outputs: open collector transistor usable for pulse, frequency, or alarm settings.

- Volumetric Pulse
- Directional Indication
- Range Indication
- Flow Rate (Frequency)
- Hardware Alarm
- High/Low Flow Alarms
- Empty Pipe

Local Converter

- Pre-programmed
- Curve-fitting algorithm to improve accuracy
- 4-20mA (1000 ohm) analog output
- RS485 port for easy connection to DCS
- Eight line graphical display
- Three key touch programming

The converter is supplied as a stand-alone IP67 enclosure or installed in optional enclosures listed.

Converter Enclosures

- IP67 Die cast aluminum - Local
- SS IP66 - NEMA 4 - Panel Mounted (optional)
- Fibreglass NEMA 4X - Panel Mounted (optional)
- Polycarbonate IP67 NEMA 6 - Panel Mounted (optional)

Electrical Connections

Compression gland seals for 0.125" to 0.375" dia. round cable.

Isolation

Galvanic separation to 50VDC between analog, pulse/alarm, and earth/ground

Ratings

- IP68 Submersible Sensor
- CE Certified - (Local Converter)

Environmental

Stainless Steel Insertion Tube: Up to 160°F (71°C) at 250 PSI

Electronics: Operating and storage temperature: -4° to 140°F (-20°C to +60°C)

Insertion Tube

Valve Size	Sensor Dia.	Total Sensor Length
4" (100mm)	1" (25mm)	8" (203mm)
6" (150mm)	1" (25mm)	8" (203mm)
8" (200mm)	1" (25mm)	8" (203mm)
10" (250mm)	1" (25mm)	8" (203mm)
12" (300mm)	1" (25mm)	8" (203mm)
16" (400mm)	1" (25mm)	8" (203mm)
20" (500mm)	1" (25mm)	10" (254mm)
24" (600mm)	1" (25mm)	10" (254mm)
28" (700mm)	1" (25mm)	10" (254mm)
36" (900mm)	1" (25mm)	12" (305mm)

Keypad and Display

Can be used to access and change set-up parameters using three membrane keys and LCD display.

Options - Local Converter

- Sun Shield
- Stainless Steel ID Tag
- Additional Sensor Cable up to 200' (for longer lengths consult factory)
- Sensor Insertion Tool

Model 106-SPI-MV

Single Point Insertion Flow Metering Valve

Dimensions

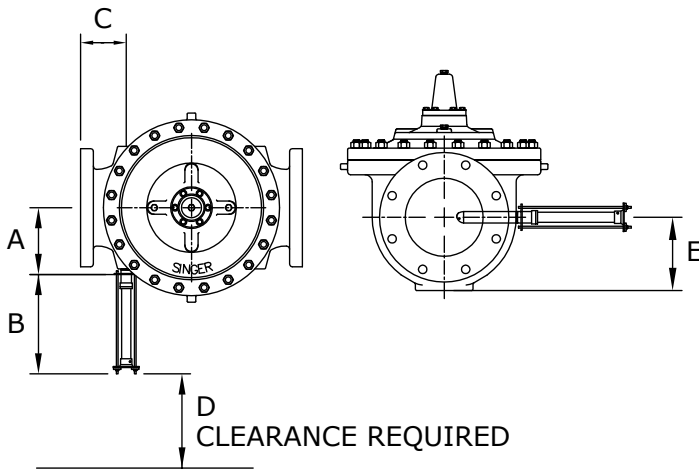

Valve Size	A	B	C	D	E
4" (100mm)	3.5" (89mm)	6.04" (153mm)	2.75" (70mm)	8" (203mm)	4.6" (117mm)
6" (150mm)	4" (102mm)	6.31" (160mm)	3.5" (89mm)	8" (203mm)	6.09" (155mm)
8" (200mm)	5.5" (140mm)	6.15" (156mm)	3.69" (94mm)	8" (203mm)	7.63" (194mm)
10" (250mm)	6" (152mm)	5.65" (143mm)	4.88" (124mm)	8" (203mm)	8.56" (217mm)
12" (300mm)	7.13" (181mm)	5.37" (136mm)	6.49" (165mm)	8" (203mm)	9.53" (242mm)
16" (400mm)	9.55" (243mm)	4.64" (118mm)	4.7" (119mm)	8" (203mm)	11.75" (298mm)
20" (500mm)	11.25" (286mm)	6.07" (154mm)	6" (152mm)	10" (254mm)	14.44" (367mm)
24" (600mm)	13.25" (337mm)	5.55" (141mm)	7.48" (190mm)	10" (254mm)	17.12" (435mm)
28" (700mm)	13.25" (337mm)	5.55" (141mm)	8" (203mm)	10" (254mm)	18.56" (471mm)
36" (750mm)	20.62" (524mm)	5.22" (133mm)	11" (279mm)	12" (305mm)	25.5" (648mm)

Notes

- All valves 6" (150mm) and larger are Single Rolling Diaphragm style
- Dimensions based on 150# Flanged bodies

Installation Details

- Allow 3 pipe diameters minimum upstream of sensor
- These units can be installed with Singer AC (Anti-Cav) cages
- Sensor can be installed on either side of valve - inlet only

Electrical

Local Converter

IP67 - Die Cast Aluminum

5.75" high x 5.75" wide x 6.69" deep
(146mm high x 146mm wide x 170mm deep)



Panel Mounted Converter

Stainless Steel IP66 - Type 304 Stainless Steel

12" high x 10" wide x 8" deep
(305mm high x 254mm wide x 203mm deep)

Fiberglass NEMA Type 4 - Compression Molded Fiberglass

14" high x 12" wide x 8" deep
(356mm high x 305mm wide x 203mm deep)

Polycarbonate IP67 - ABS

7.4" high x 7.4" wide x 7.1" deep
(188mm high x 188mm wide x 180mm deep)

WHY SINGER DOES IT BETTER!

- Insertion design for total accessibility
- Price is independent of control valve size
- No moving parts
- Does not require recalibration in the field

Model 106-SPI-MV Single Point Insertion Flow Metering Valve

106-SPI-MV	Flow Capacity (See 106-PG in Main Valve section for other valve data)									
	4 in	6 in	8 in	10 in	12 in	16 in	20 in	24 in	28 in	36 in
Size (inches)	4 in	6 in	8 in	10 in	12 in	16 in	20 in	24 in	28 in	36 in
Size (mm)	100 mm	150 mm	200 mm	250 mm	300 mm	400 mm	500 mm	600 mm	700 mm	900 mm
Minimum (USGPM) Flat Diaphragm	10	20	40	-	-	-	-	-	-	-
Minimum (USGPM) Rolling Diaphragm	-	0.5	1	3	3	3	10	10	10	20
Minimum (L/s) Flat Diaphragm	0.6	-	-	-	-	-	-	-	-	-
Minimum (L/s) Rolling Diaphragm	-	0.03	0.06	0.2	0.2	0.2	0.6	0.6	0.6	1.3
Maximum Continuous (USGPM)	800	1,800	3,100	4,900	7,000	11,000	17,500	25,000	33,600	55,470
Maximum Continuous (L/s)	50	114	196	309	442	694	1,104	1,577	2,120	3,500

1. Usually operating in the continuous "C", service range up to 20 ft/s (6 m/s) - refer to chart and/or performance curves.
2. Ensure the maximum working pressure rating of the valve exceeds the maximum operating pressure

Ordering Requirements

At the time of ordering, please be prepared to provide the following information:

- Valve size
- Fluid
- Pressure
- Cable length
- Minimum flow
- Temperature

Schematic Drawing

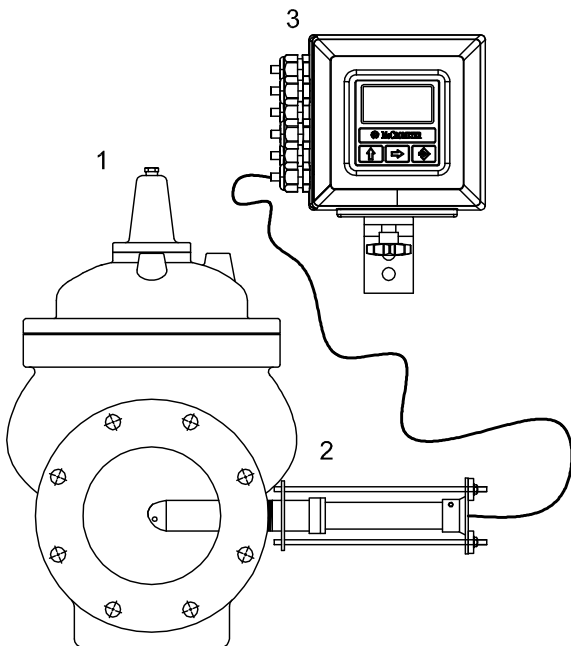

1. Main Valve - Model 106-PG
2. Model SPI - Single Point Insertion Meter
3. Local Converter - Flow Indicating Transmitter

Note: Local IP67 Converter is standard.

Optional enclosures are:

- Stainless Steel IP66 - NEMA 4 - Panel Mounted (optional)
- Fibreglass NEMA 4X - Panel Mounted (optional)
- SS IP66 - NEMA 4X - Panel Mounted (optional)
- Polycarbonate IP67 NEMA 6 - Panel Mounted (optional)

Model 106-SPI-MV

Single Point Insertion Flow Metering Valve

Specifications

MAIN VALVE BODY

- Valve(s) shall be a hydraulically operated globe valve. The inner valve assembly shall be top and bottom guided by means of easily replaceable bearing bushings. The inner valve assembly shall be the only moving part and shall be securely mounted on a 316 stainless steel stem. The stainless steel stem shall be provided with wrench flats on all valves 4" (100mm) to 8" (200mm), for ease of assembly and maintenance.
- All pressure containing components shall be constructed of ASTM A536-65/45/12 ductile iron. The flanges shall be designed to ANSI Class 150 or Class 300 standards. Flange drilling to ANSI shall be standard however British, ISO and other drillings shall be available upon request.
- Valve(s) shall have a protective fusion bonded epoxy coating internally and externally. The protective fusion bonded epoxy coating shall conform to the ANSI/AWWA C116/A21.16 (current version) specification.
- 4" (100mm) Valve(s) shall provide smooth "frictionless" motion with actuation being achieved by the use of a flat style EPDM diaphragm. They shall be constructed of nylon fabric bonded with synthetic rubber. The diaphragms shall not be used as a seating surface. No lip seals or packing may be used to seal the actuator.
- Valve(s) 6" (150mm) and larger shall provide smooth "frictionless" motion and maximum low flow stability with actuation being achieved by the use of the Singer rolling diaphragm technology. The diaphragms shall not be used as a seating surface. No lip seals or packing may be used to seal the actuator.
- The valve cover shall have a separate stem cap giving access to the stem for alignment check, spring installation and ease of assembly.
- On valve(s) 4"(100mm) and larger, bonnets shall be accurately located to bodies utilizing locating pins. Locating pins shall eliminate corrosion resulting from the use of uncoated ductile iron to ductile iron surfaces.
- Valve(s) 4"(100mm) and larger shall have the 316 stainless steel seat, bolted in place, utilizing "Spiralock" thread tapping technology. The 316 stainless steel seat ring shall be easily replaceable without special tools.
- The valve(s) shall form a drip tight seal between the stationary stainless steel seat ring and the resilient disc, which has a rectangular cross-section and is retained by clamping on three and one half sides. The resilient disc shall be constructed of Buna or EPDM for normal service conditions.
- All external fasteners shall be 18/8 stainless steel with 18/8 washers.
- All repairs and maintenance shall be possible without removing the valve from the line. To facilitate easy removal and replacement of the inner valve assembly and to reduce unnecessary wear on the guide, the stem shall be vertical when the valve is mounted in a horizontal line.
- Each valve shall be tested prior to shipment. The standard test shall include a pressure test and a full functional, operational test when pilots and accessories are fitted to suit a particular application.
- The valve(s) shall be covered by a minimum three year (3) warranty against defects in materials and workmanship. The stainless steel seat ring shall be covered by a lifetime replacement warranty.

MAGNETIC FLOW METER

- The valve shall be installed with a 1" (25mm) Single Point Insertion Magnetic Flow Meter in one of the inlet body tapings.
- Unit will be factory installed and programmed with correlative factors for Main Valve body flow profile.
- The flow meter shall consist of two components: an electromagnetic sensor and a converter.
- The 1" (25mm) electromagnetic sensor shall be capable of operating in valves from 4" (100mm) to 36" (900mm).
- The flow meter shall determine the volumetric flow rate by means of the Continuity Equation where flow rate "Q" equals mean velocity "V" times cross sectional area "A" ($Q = V \times A$). The velocity measurement must be taken at a known location, then, through empirically established equations, the sensed velocity will be converted to a mean velocity.
- The flow meter converter shall be microprocessor based with a keypad for instrument set up and LCD displays for totalized flow, flow rate engineering units and velocity. The converter shall power the flow-sensing element and provide a galvanically isolated Dual 4-20mA output.
- It shall be possible, in the test mode; to easily set the converter outputs to any desired value within the range. The 4-20mA scaling, time constants, pipe size, flow proportional output, engineering units and test mode values shall be easily set via the keypad and display.
- Four separate fully programmable alarm outputs shall be provided to indicate empty pipe, forward/reverse, polarity (normally open/close), analog over-range, fault conditions, high/low flow rates, percentage of range, and pulse cutoff. The converter shall periodically perform self-diagnostics and display any resulting error messages. All set up data and totalizer values may be protected by a password.
- The flow-sensing element shall be of an electromagnetic single point type design and factory calibrated to traceable standards, such as NIST. The sensor shall be made of a polyurethane with pure carbon electrodes exposed to flow.
- To eliminate erroneous readings due to pipe wall effects, the sensor must have its electrodes located at least 3/16" from pipe wall and be designed with a curved tip shape, so as not to collect debris while in the operating position. Flat tipped or Doppler sensors shall not be acceptable.
- The sensor cable is 20 feet (6m) of multi-conductor, abrasive resistant, PVC jacketed submersible cable flexible to -40°F/C. The sensor cable shall be permanently bonded to the sensor. Additional sensor cable, up to 200 feet (61m), shall be available as an option.
- The insertion tube and restraining rods assembly shall be provided for the smooth installation and operation of the velocity sensor and shall be of sufficient length to allow a full profile of the flow conduit. The stainless steel insertion tube shall be rated for 250 PSI (1,724 Kpa) @ 160° F (71°C).
- Hardware must allow sensor to be secured by bolts when sensor is being inserted and retracted. A stainless steel compression seal assembly shall also be supplied.
- No flow meters with accuracies expressed as a percentage of full scale will be accepted and flow meter must be NIST Traceable.

Singer Valve Inc. will not act for or makes no warranty, either expressed or implied, on behalf of McCrometer. Singer Valve Inc. will warranty main valve as covered in our standard warranty. Items manufactured by McCrometer will be covered under their standard warranty. In no event shall Singer Valve Inc. be liable to anyone for special, collateral, incidental, or consequential damages in connection with or arising out of use of this equipment. Singer Valve Inc. Reserves the right to revise and improve its products as it sees fit.

Canada Head Office

12850 – 87th Avenue
Surrey, BC V3W 3H9
Canada

Tel: (604) 594 5404
Fax: (604) 594 8845
Toll Free Fax (Canada & USA):
1 800 663 7266
✉ singer@singervalue.com

USA Office

Mailing Address
Singer Valve LLC
PO Box 668588
Charlotte, NC 28266

Shipping Address
1873 Scott Futrell Drive
Charlotte, NC 28208

Tel: (704) 391 5785
Fax: (704) 391 5768
Toll Free (USA):
1 888 764 7858
✉ mark@singervalue.com

United Arab Emirates Office

Singer Valve Middle East FZE
PO Box 121326
SAIF Free Zone
Q3 – Unit 94
Sharjah International Airport
FREE ZONE
Sharjah, UAE

Tel: +971 6 557 8116
Fax: +971 6 557 8117
✉ canadian@singervalue.com

Malaysia Office

SVM Water Controls Sdn. Bhd.
No 6, Jalan MJ 4, Medan Maju Jaya,
Batu 7, Jalan Kelang Lama
46200 Petaling Jaya
Selangor Darul Ehsan, Malaysia

Tel: 603 7784 4043 / 7784 4044
Fax: 603 7781 8312
✉ svmwc@tm.net.my

China Office

Singer Valve (Taicang) Company Ltd.
No.88 East Dalian Road,
Taicang, Jiangsu, China

Tel: 86 512 5320 6188
Fax: 86 512 5320 6099
✉ lijun@singervalue.com

